



11° EDIZIONE
22 OTTOBRE - 20 DICEMBRE

FESTIVAL 2024
DELLA
CULTURA
TECNICA

La partecipazione tiene banco:
un'esperienza di scuola diffusa



Il Mattei non è solo scuola, ma comunità

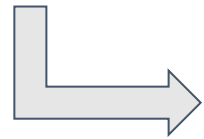

che apprende

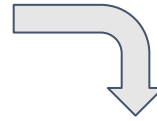

che ha cura degli spazi esterni

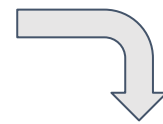

e che li vuole migliorare per

l'outdoor learning



con attenzione alle disabilità



Perché questo logo?



I.I.S. Mattei

+

I.C. Rodari

+

Comune di San Lazzaro
di Savena (BO)

=

E' nata la Scuola Diffusa

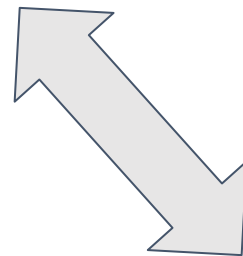

“che ha cura degli spazi
esterni e che li vuole
migliorare”

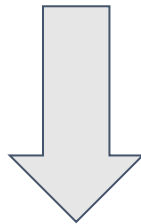

riqualificazione di una zona
verde attorno alle scuole

Come?

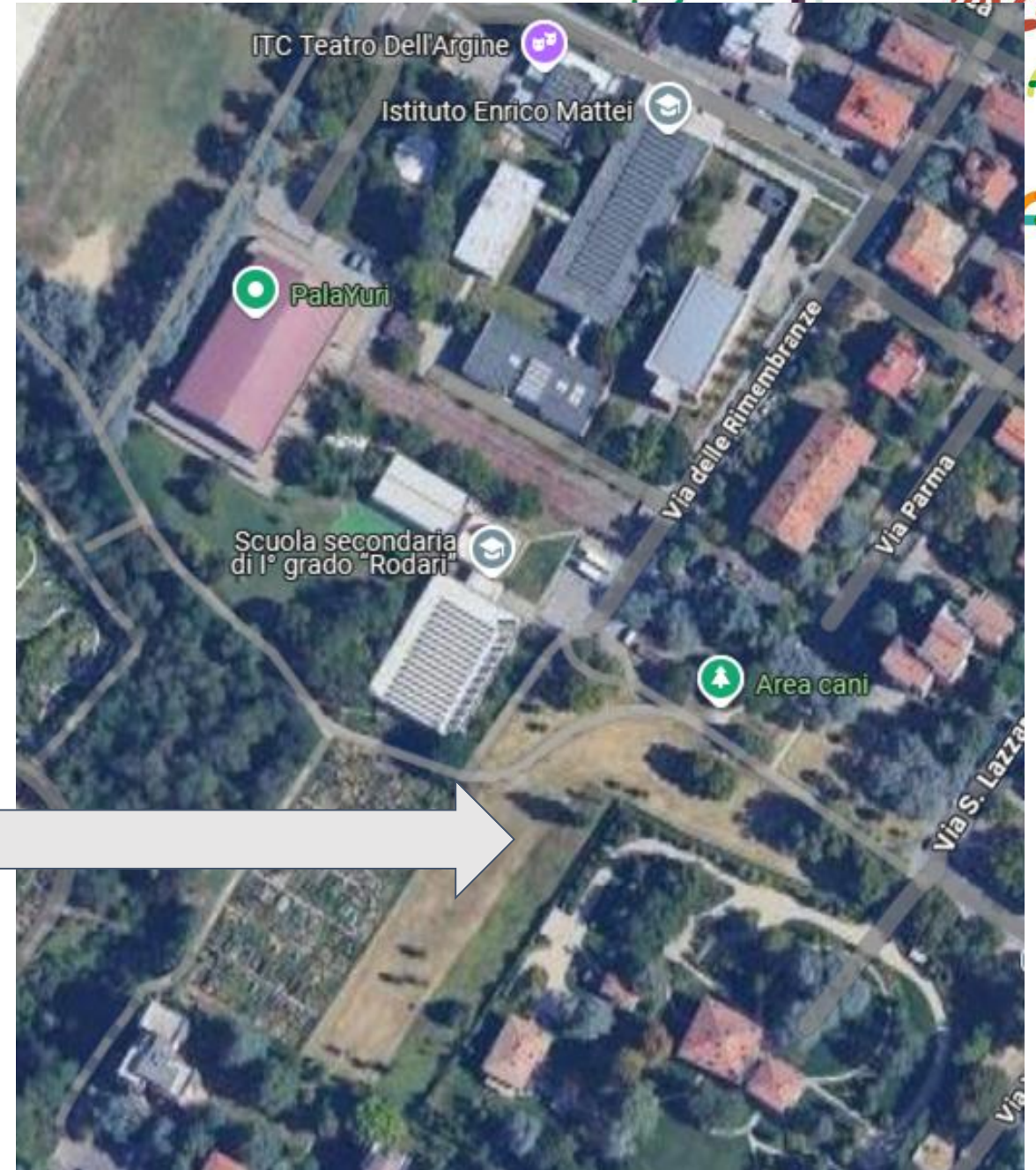
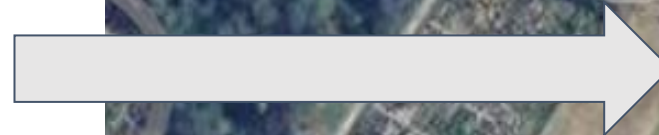

1° step: la planimetria - creazione dello strumento

Tramite la stampante 3D, delle alunne e degli alunni del Mattei hanno progettato e realizzato due teodoliti

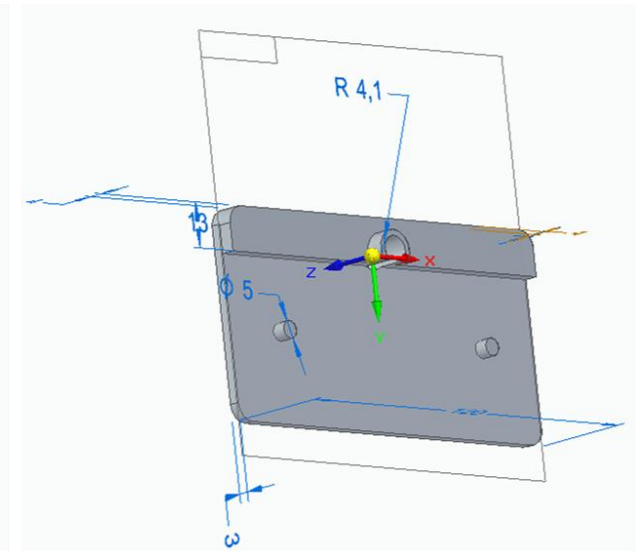
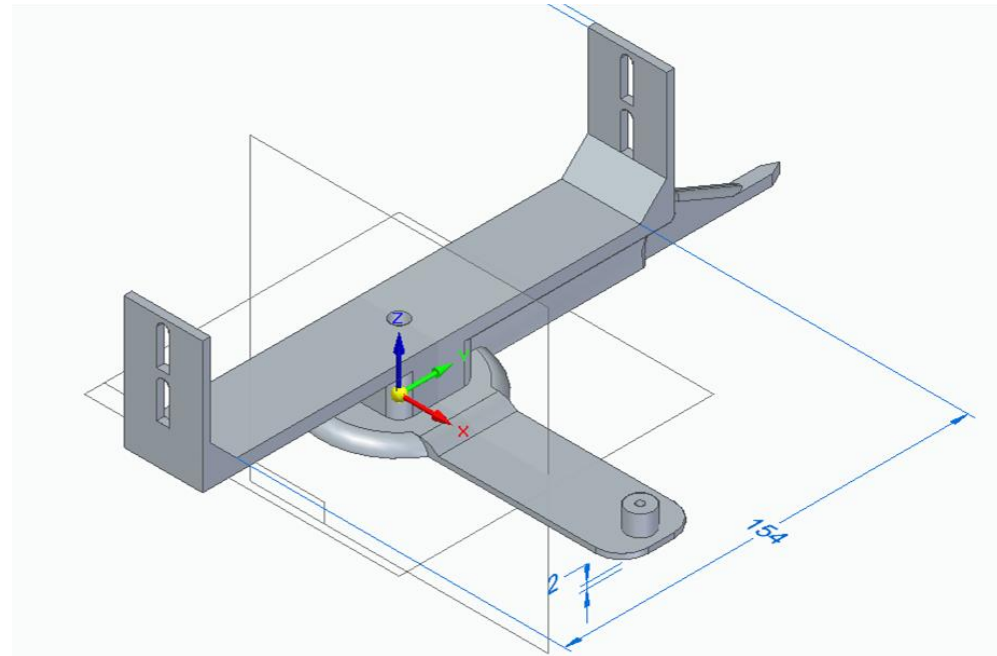
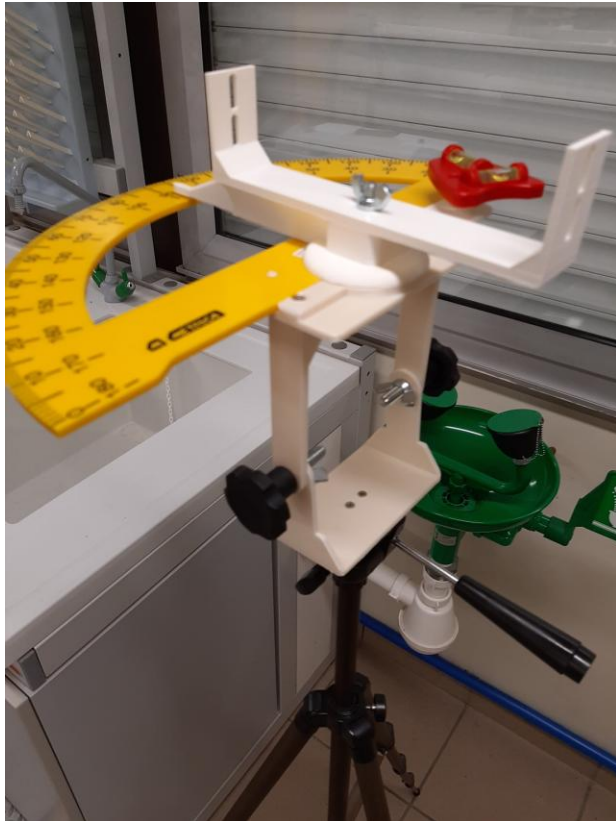

il teodolite

2° step: la planimetria - misurazioni via triangolazione



3° step: ...ecco la planimetria



...dopo calcoli e disegni eccola

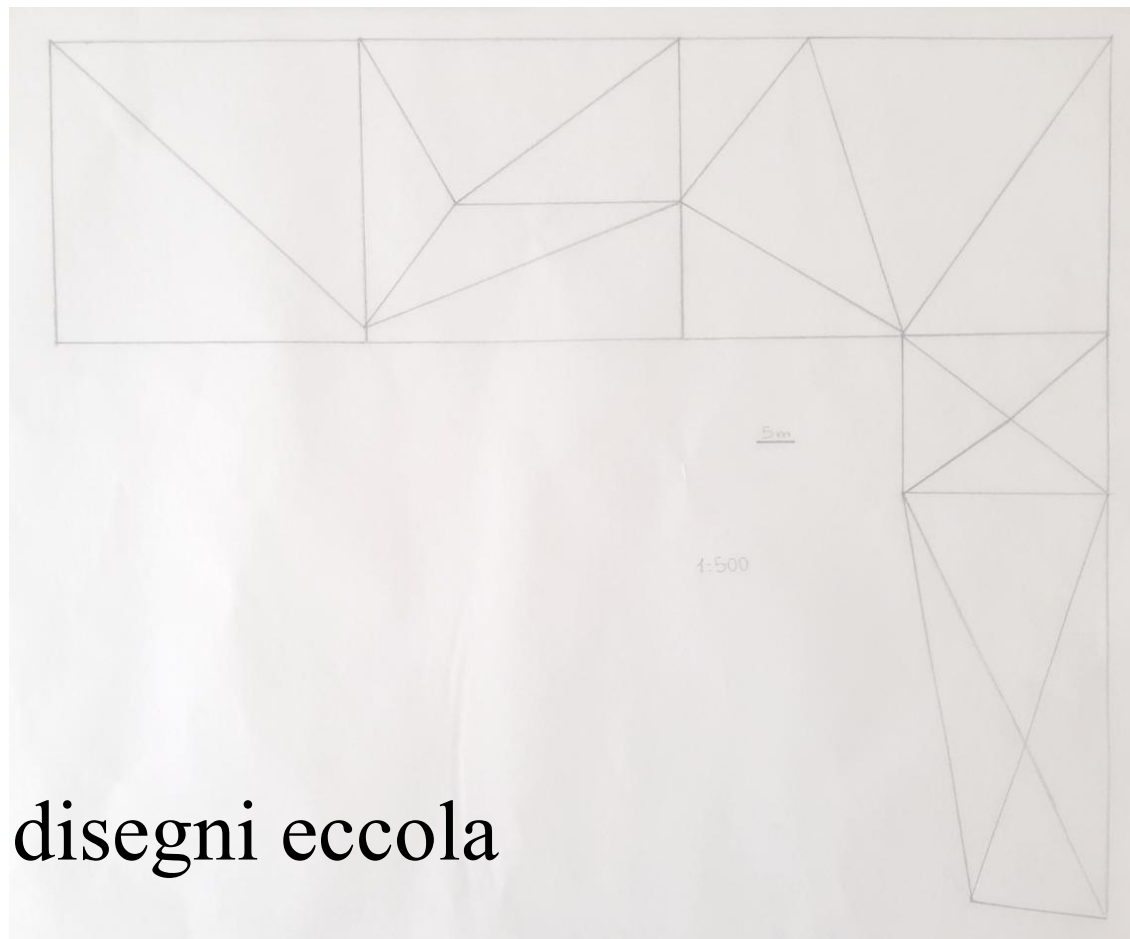

la planimetria - confronto

Il confronto tra la
planimetria e
l'immagine
satellitare...



ci sono degli errori, ma
comunque il risultato è
soddisfacente



4° step: riqualificazione



chiosco



beach volley



campo da bocce



calcio a 5

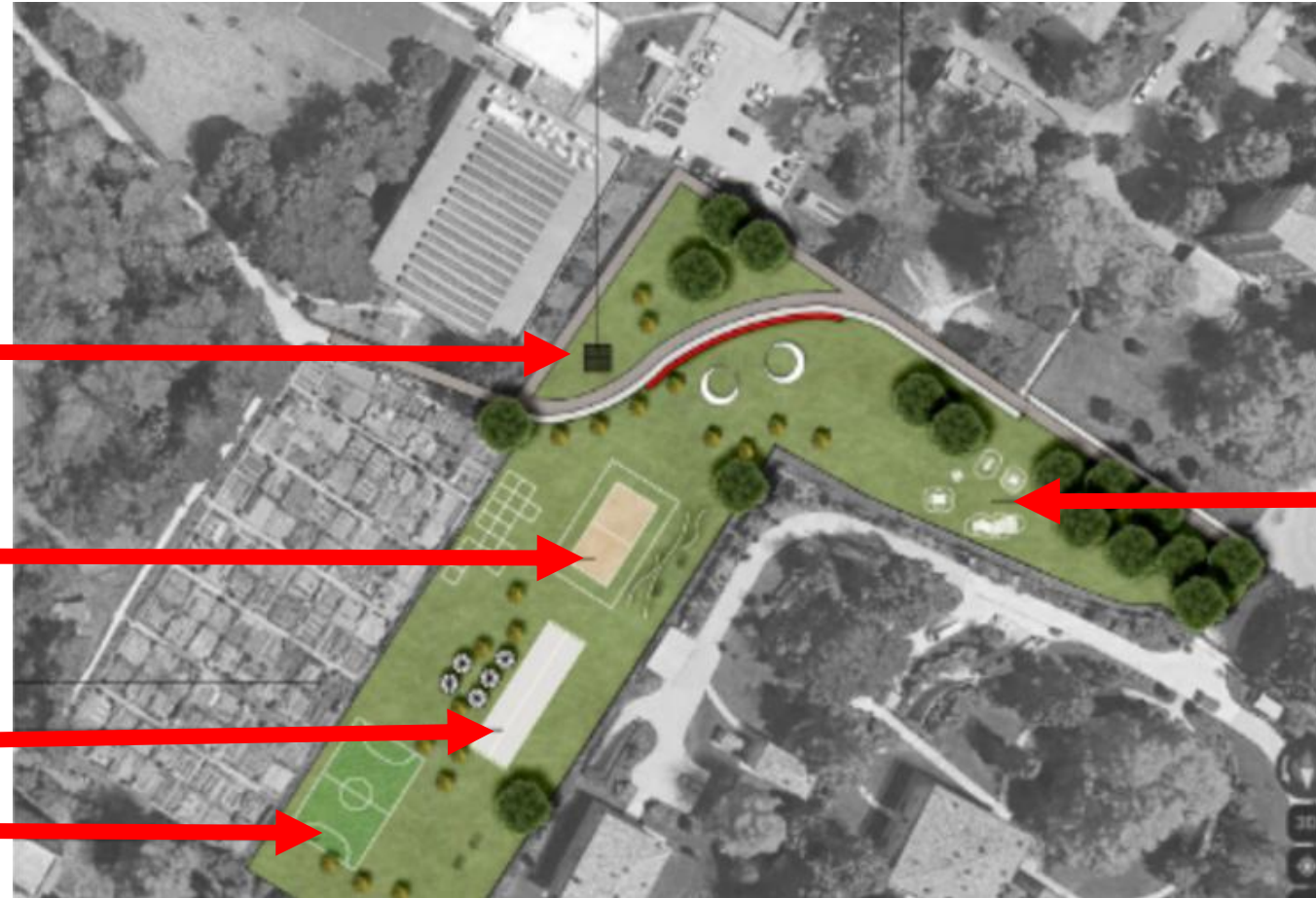

zona calisthenics

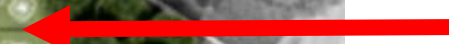



Ma anche riqualificazione di...

riqualificazione della pista di atletica del Mattei

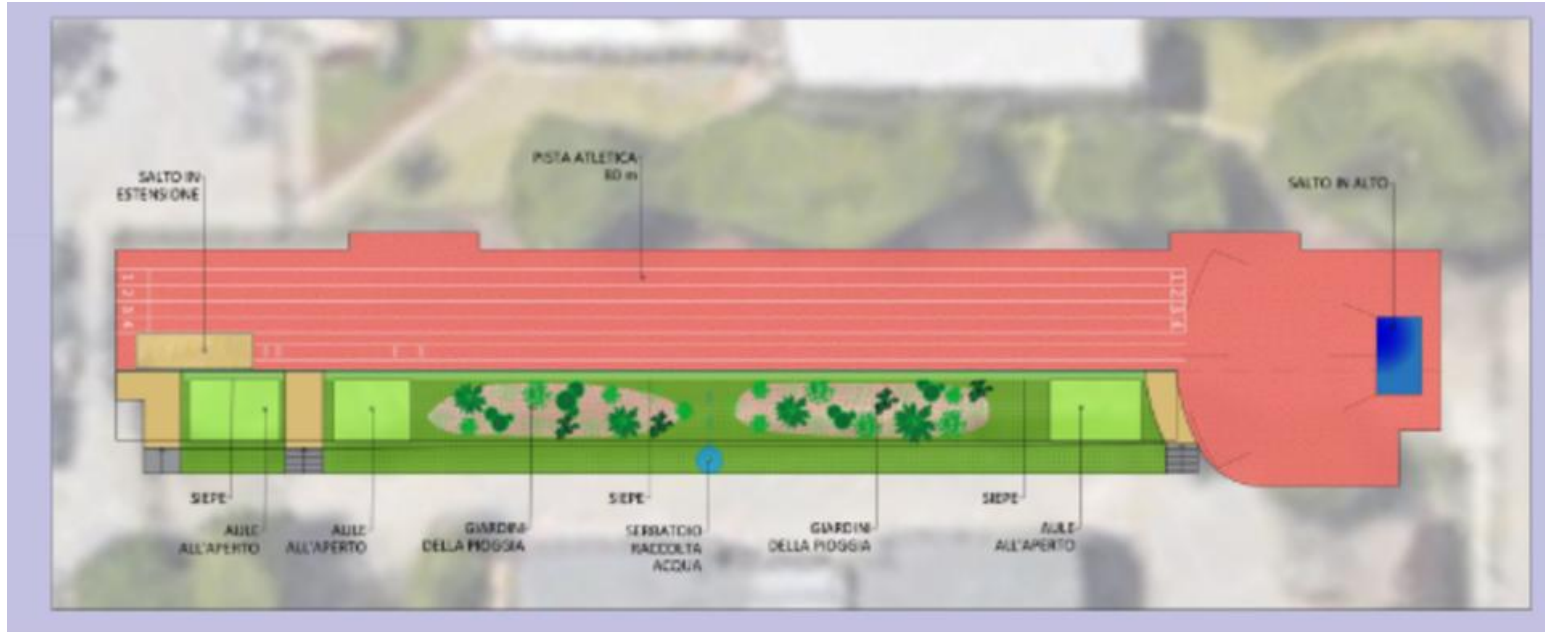

Una nuova pista con siepi
e con un sistema per la
raccolta dell'acqua
piovana

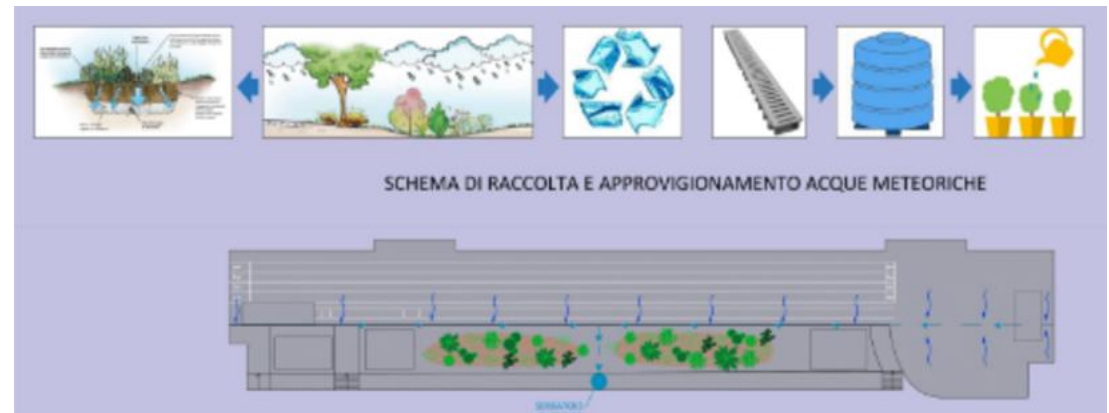

riqualificazione degli spazi esterni del Mattei



E' nata l'aula "Samurai"

riqualificazione degli spazi esterni del Mattei



E' nata l'aula "Scienziato Pazzo"



La Scuola Diffusa

FESTIVAL 2024
DELLA
CULTURA
TECNICA



e ancora...

M
L
Scu

FESTIVAL 2024 DELLA CULTURA



e ancora...

Nudgethon



“con attenzione alle disabilità”



Come?



Sostituzione di parti di
prato per creare dei
corridoi

Inserimento
di rampe

...e per favorire
l'autonomia...

Con l'aiuto del Dott. Davide Stasolla, Amministratore presso Abitech Srl e persona tetraplegica e del Geometra Scanavacca della Città Metropolitana progetteremo l'accessibilità alle aule esterne e la cura del cortile come bene comune. Davide Stasolla



Creazione di
una pinza
particolare

↳ Come?

Tramite la stampa 3D, delle alunne e degli alunni del Mattei hanno progettato e realizzato una pinza per raccogliere oggetti da terra



ovvero...



FESTIVAL 2024
DELLA
CULTURA
nica



11° EDIZIONE
22 OTTOBRE - 20 DICEMBRE

FESTIVAL 2024
DELLA
CULTURA
TECNICA

Grazie per l'attenzione.....





11° EDIZIONE
22 OTTOBRE - 20 DICEMBRE

FESTIVAL 2024
DELLA
CULTURA
TECNICA

Avete delle domande?

